

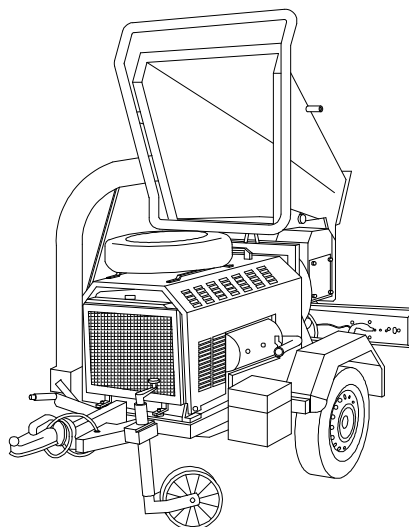

## CIPPATRICE CIPPO 15



- Elettrico - Electric 15 HP / 11 KW 380 V
- Benzina - Petrol 24 HP / 17 KW HONDA GX 670
- Diesel 27 HP / 20 KW Lombardini FOCS 1003
- Diesel 29 HP / 22 KW Kubota D 1105-E
- Diesel 40 HP / 29 KW Lombardini CHD 1603
- Trattore - Tractor 40÷60 HP
- Impianto idraulico indipendente - Independent hydraulic feed roller
- Rullo idraulico di alimentazione con leva di comando e regolazione - Hydraulic feed roller with regulations and control lever
- Disco cippatore - Chipper disc
- Carrello con ruote e timone - Chassis with wheels and drawbar
- Tubazione di scarico a mt 2,40 - Output pipe mts 2,40
- Produzione - Production 10÷12 m<sup>3</sup> / h

	Lame N°	C/lame N°	Martelli N°	Ø Triturabile	Ø Cippabile	Peso Kg	Dimensioni cm			Imballo cm		
	2	1	-	-	15	520	Lar	Lun	Alt	Lar	Lun	Alt
							125	207	210	300	130	185
No. Blades	No. C/blades	No. Hammers	Ø Triturable	Ø To be cut	Kg Weight	cm Dimensions			cm Packing			
						Bre	Len	Hig	Bre	Len	Hig	



Scheda n. CP15-01 | Cippatrice Cippo 15

Caravaggi Srl

Via Monte Adamello, 20 - 25037 Pontoglio - BS (ITALY)

Tel. +39 030 7470464 - Fax +39 030 7470004 - Email [info@aravaggi.com](mailto:info@aravaggi.com)